



Its all about taking Shortcuts.....

- What the "Focus" is and how to manipulate it in AccuDraw?
- How to enter distances and angles in AccuDraw?
- What indexing is?
- What context sensitivity is?
- When and how to enter shortcuts?
- How to use the SmartLock?
- How to set and move AccuDraw's origin?
- How to select an ordinate of a point?
- How to use the "T" and "V" shortcuts?
- How to use the "RQ" shortcut?
- How to enter absolute coordinates?
- How to display a list of AccuDraw's shortcuts?
- How to display AccuDraw's settings?
- How to use AccuDraw's pop-up calculator?

WWW.BENTLEY.COM 

Its all about taking Shortcuts.....

- How to define shortcuts ?
`ac=armorthplan;aa=0;accudraw dialog;accudraw setorigin;accudraw rotate top;%d;accudraw rotate view;accudraw quite;reset`
- How to use RE or RV ?
- How about RX, RY, RZ or E ?
- How about HA (Put it on hold), HS (On/Off AccuSnap) and HU (Off AccuSnap until restart of AccuDraw)?

WWW.BENTLEY.COM 

Customize your Ride.....

- Color
X, Y, Hilite, Frame, Fill
- Size of AccuDraw Dialog, S, M, L
- Size of the Compass via Keyin, ranges from 6 to 399
`accudraw settings size 35`

WWW.BENTLEY.COM 

Did you know ?

To set Origin, instead of <O> or Spacebar+<O> CTRL+Tentative.....

Spacebar also sets the focus to AccuDraw.

WWW.BENTLEY.COM 

Coordinate and Angle Entry

Handy Stuff that's Worthy of Your Time...

Degrees

When entering angles in DD MM SS format in AccuDraw, you can use either the caret symbol (^) or a semi-colon (;) to indicate degrees.

Example: N89°59'42"E may be entered as N89^59'42"E or N89;59'42"E

Using Angle Quadrants

Rather than entering the letters N, S, E, and W when entering bearings, you can enter quadrant numbers as a shortcut:

- NE=1
- NW=2
- SW=3
- SE=4

Example: N89°59'42"E may be entered as 1 89;59'42"

WWW.BENTLEY.COM 

Coordinate and Angle Entry

Continued...

Rather Not Use the Colon?

The shift key must be used to type a colon. This can be avoided by using one of the following substitutes:

- a semi-colon (;)
- an apostrophe (')
- or two periods (..)

Change the AccuDraw Window to N and E

Use these key-ins to switch AccuDraw between Northing/Easting and X/Y:

accudraw settings northeast
accudraw settings xy

Page Up/Down for last few distances

WWW.BENTLEY.COM 

Basic Drawing Plane Rotation

Continued...

Placing the Front Wall

In like manner, place the front wall. The height of the front wall should be 8' and the color should be 7 (cyan).

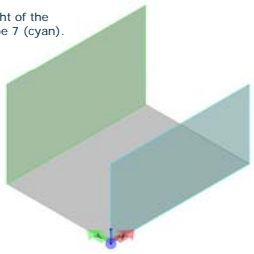

131 WWW.BENTLEY.COM 

Basic Drawing Plane Rotation

Continued...

Placing the Side Walls

Use Place SmartLine to create a shape for the side walls.

1. Set the active color to 32 (light gray).
2. Start at Point 1. AccuDraw should be in the top drawing plane.
3. Lock the Z axis and hover over point 2. Notice how the X and Y ordinates of point 2 are used, but the Z ordinate of point 1 is retained.*
4. Type "S" -- the side rotation shortcut, and complete the shape by entering vertices at points 3 and 4 and closing the shape by returning to point 1.

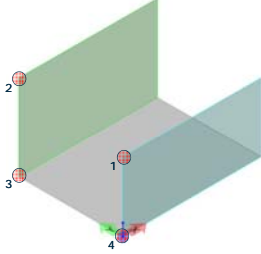

*Locking the Z axis and rotating to the side drawing plane is not a necessary step to complete the shape, but is here to demonstrate "ordinate projection" and the "Side" rotation functionality.

134 WWW.BENTLEY.COM 

Basic Drawing Plane Rotation

Continued...

Finish the Side Walls

After the first side wall is completed, create a second in like manner.

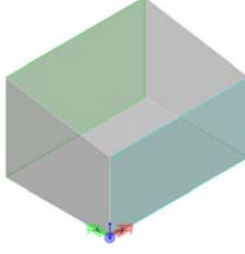

135 WWW.BENTLEY.COM 

Basic Drawing Plane Rotation

Continued...

Add Doors and Windows

Using the Side and Front drawing planes (shortcuts "s" and "f") create shapes for a 7' x 3' door and a 2' x 4' window. Use AccuDraw to position the door and window shapes in the wall planes as illustrated.

Once the shapes are positioned, use the group hole  command (found on the Groups tool bar) to create openings in the walls.

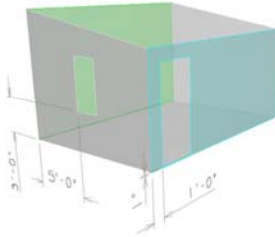

AccuDraw and the ACS

What is an ACS?

3D Auxiliary Coordinate Systems

An auxiliary coordinate system (ACS) is a coordinate system with an orientation, and/or an origin, different from those of the DGN file coordinates (the Global system). Although not exclusively a 3D concept, an ACS is most useful in 3D modeling as a drawing aid.



By using an ACS that corresponds to the location and orientation of a particular element, you can enter data points relative to parts of the model rather than the global origin.

Although using ACSs may seem complicated, AccuDraw uses them as a basic part of its 3D functionality. It is not necessary to learn much about ACSs to use them effectively with AccuDraw; however, we will explore some basic functionality which is useful in a 3D environment.

AccuDraw and the ACS

Defining a new Drawing Plane using the "RA" Shortcut

Adding a Roof

Although we can use the Place Block command with the Method set to "Rotated" to quickly throw a shape on the roof, use the "Orthogonal" method and note the behavior of the command. Try the command with and without AccuDraw. What problems do you encounter?

Often it is useful to work in a design plane other than the Top, Front or Side. AccuDraw's "RA" (Rotate ACS) shortcut enables us to quickly define a new design plane based on three points.

After we define a new drawing plane we'll add the roof.

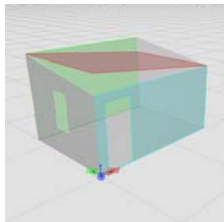

Yikes! We would have had a better result if we had rotated our drawing plane first using AccuDraw's "RA" shortcut.

AccuDraw and the ACS

The Auxiliary Coordinates Dialog Box

Managing Coordinate Systems

The Auxiliary Coordinates Dialog Box (accessed from the *Utilities* pull-down menu) is used to manage user-defined coordinate systems. As you can see, the "Roof" coordinate system we saved is here. The main window of the dialog box is broken into two sections:

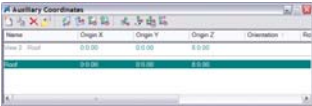

The top section, displaying "View 2: Roof" displays information about the last view in which a data point was entered. Different views can implement different coordinate systems. Coordinate systems can even "follow" your view. This feature is controlled by the "Toggle View Independent" option in the Auxiliary Coordinates right-click menu.

The bottom section holds a list of named coordinate systems that have been saved. Double clicking a named coordinate system will apply it to the current view.



To reset a view to the Global Coordinate System, right-click the view name in the top section of the dialog box and select "Reset To Global".

© 2011 WWW.BENTLEY.COM 

AccuDraw and the ACS

Changing Coordinate Systems

Reset, Create and Restore Coordinate Systems

- From the Auxiliary Coordinates dialog box, reset your current view to global.
- Next use the Copy ACS tool  to create a copy of the current (Global) ACS.
- Name the new ACS "Global".
- Switch between different systems by double clicking them in the Auxiliary Coordinates dialog box.
- Try using the Select ACS tool  to select a different ACS.

Use AccuDraw's "GA" Shortcut to Recall an ACS

- Once again, from the Auxiliary Coordinates dialog box, reset your current view to global.
- Close the Auxiliary Coordinates Dialog box.
- In AccuDraw, enter the "GA" Shortcut.
- Restore the ACS "Roof". Be sure both *Origin* and *Rotation* are checked.



© 2011 WWW.BENTLEY.COM 

AccuDraw and the ACS

Continued...

Add Skylights in the Roof Plane

Create two 2' x 5' shapes for skylights and position them in the roof plane. Use the Keypoint Snap and Keypoint Snap Divisor to position the skylights evenly in the roof plane. The Keypoint Snap Divisor dialog box is displayed by using the AccuDraw's "K" shortcut.

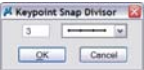
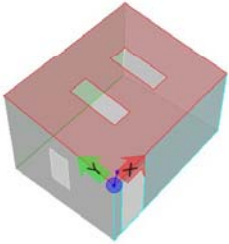
Once the shapes have been positioned, use the group hole tool to punch holes in the roof with the shapes.

© 2011 WWW.BENTLEY.COM 

Modifying Elements with AccuDraw

The Element Selection Tool with AccuDraw

Create a Roof Overhang

1. With the Element Selection tool select the roof plane.
2. Click on a corner handle – Note how AccuDraw aligns itself with element being modified.
3. Using AccuDraw add 6" of overhang to each edge of the roof plane.

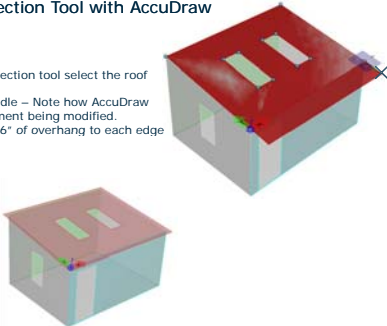

25 | WWW.BENTLEY.COM 

Modifying Elements with AccuDraw

Continued...

Solidify the Planar Elements

Use the Solid by Extrusion tool  to add thickness to the roof, walls and slab. At the outset, do not check any boxes in the tool settings and leave the scale values set to one.

Starting with the roof, extrude the roof plane straight up 1'. You will have to adjust AccuDraw's drawing plane in order to do this as initially AccuDraw will orient itself perpendicular to the roof plane.

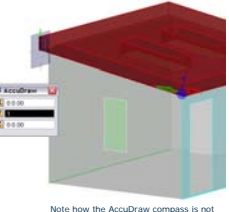

Note how the AccuDraw compass is not perpendicular to the roof plane.

Once the roof is done, using Solid by Extrusion tool, "thicken" the walls of the shed by 6" to the inside and thicken the floor slab downward by 6". This time in the tool settings, check and set the distance to 0:6. Also make sure *Orthogonal* is checked.

26 | WWW.BENTLEY.COM 

Modifying Elements with AccuDraw

Finishing the Shed and More to try...

Continuing with the Selection Tool...

Using the selection tool, shorten the two side walls by 6" on each end so they won't intersect with the front and back wall. You may use AccuDraw or snaps to do this.

More to try...

Using AccuDraw and the Selection tool, select a handle on the corner of the floor slab and make it 2" thicker.

Select the wall with the door opening. Activate the four handles on the door. Use AccuDraw to move the door opening 2" toward the center of the wall.

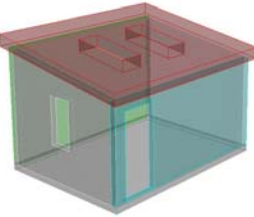

27 | WWW.BENTLEY.COM 

Exploring All Things Z

Sticky Z

When *Sticky Z* is engaged the Z axis will remain locked through consecutive operations. Normally, locks are cleared when you enter a data point. This setting is useful, for example, where you want to draw on the one plane (that is, you want to lock Z=0), while snapping to elements that are on another plane. With *Sticky Z Lock* enabled, the Z value will remain locked until you turn it off.

Sticky Z is enabled by checking the "Sticky Z Lock" on the AccuDraw Settings' operation tab. When engaged, the AccuDraw Compass will display with an inner circle or square.

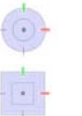

Appearance of AccuDraw's compass when Sticky Z is engaged.

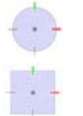

Appearance of AccuDraw's compass when Sticky Z is disengaged.



Operation tab of the AccuDraw Settings dialog box. Use the shortcut "OS" to display this dialog box.

© 2009 BENTLEY SYSTEMS, INC. WWW.BENTLEY.COM

AccuDraw Shortcuts

V = View Rotation
Rotates the compass to the View axes.

T = Top Rotation
Align the compass with the axes in a standard Top/Bottom view.

F = Front Rotation
Align the compass with the axes in a standard Front/Back view.

S = Side Rotation
Align the compass with the axes in a standard Left/Right view.

B = Base Rotation
Rotates the drawing plane to align with the active ACS, or to a rotation of the view.

E = Cycle Rotation
Rotates between three main planes: top, front, and side. <E> also works when your original plane is an ACS or context rotation, so you do not have to use RX, RY to rotate to a 90° plane from the ACS axis.

Z = Toggle Z lock
Toggles the locking of the Z field.

LP = Lock ACS Plane and ACS Plane Snap
Toggles ACS Grid Plane lock, which toggles the ACS Plane and ACS Plane Snap locks, and the Grid view attribute for all views.

LA = Lock ACS Plane
Toggles ACS Plane lock.

LS = Lock ACS Plane Snap
Toggles ACS Plane Snap lock.

LZ = Sticky Z Lock toggle
Toggles Sticky Z Lock, which can be used in conjunction with ACS Plane Snap Lock to force a series of snap points to lie on the active ACS' XY plane (Z=0) or can be used without the ACS plane.

© 2009 BENTLEY SYSTEMS, INC. WWW.BENTLEY.COM

AccuDraw Shortcuts

RA = Rotate to ACS
Used to permanently rotate the drawing plane. Because it rotates the current ACS, this rotation will still be active after the tool in use is exited. If on, the tool setting Use Current Origin causes the drawing plane origin to be used as the x-axis origin, thereby eliminating the need to enter an extra data point. Of course, in many cases it is desirable to be able to define the x-axis origin at a different location than the drawing plane origin.

GA = Get Saved ACS
Lets you select a saved Auxiliary Coordinate System.

WA = Write (Save) ACS
Lets you save the drawing plane alignment as an ACS.

RC = Rotate to Current ACS
Rotates the drawing plane to the current ACS.

RE = Rotate to Element
Rotates the drawing plane to match the orientation of a selected element.

© 2009 BENTLEY SYSTEMS, INC. WWW.BENTLEY.COM
